

Morskate®

Gedreven door techniek



De status van een machine op je smartphone?

De Beegle: ons plug & play machine monitoring systeem

Meer weten? www.beegle.nl

Morskate®



LINEA CONVEYORS • STELO FERRO
design ribassato per facilità di regolazione

CONVEYORS LINE • STEEL SCREW
low profile to ease the adjustment operation

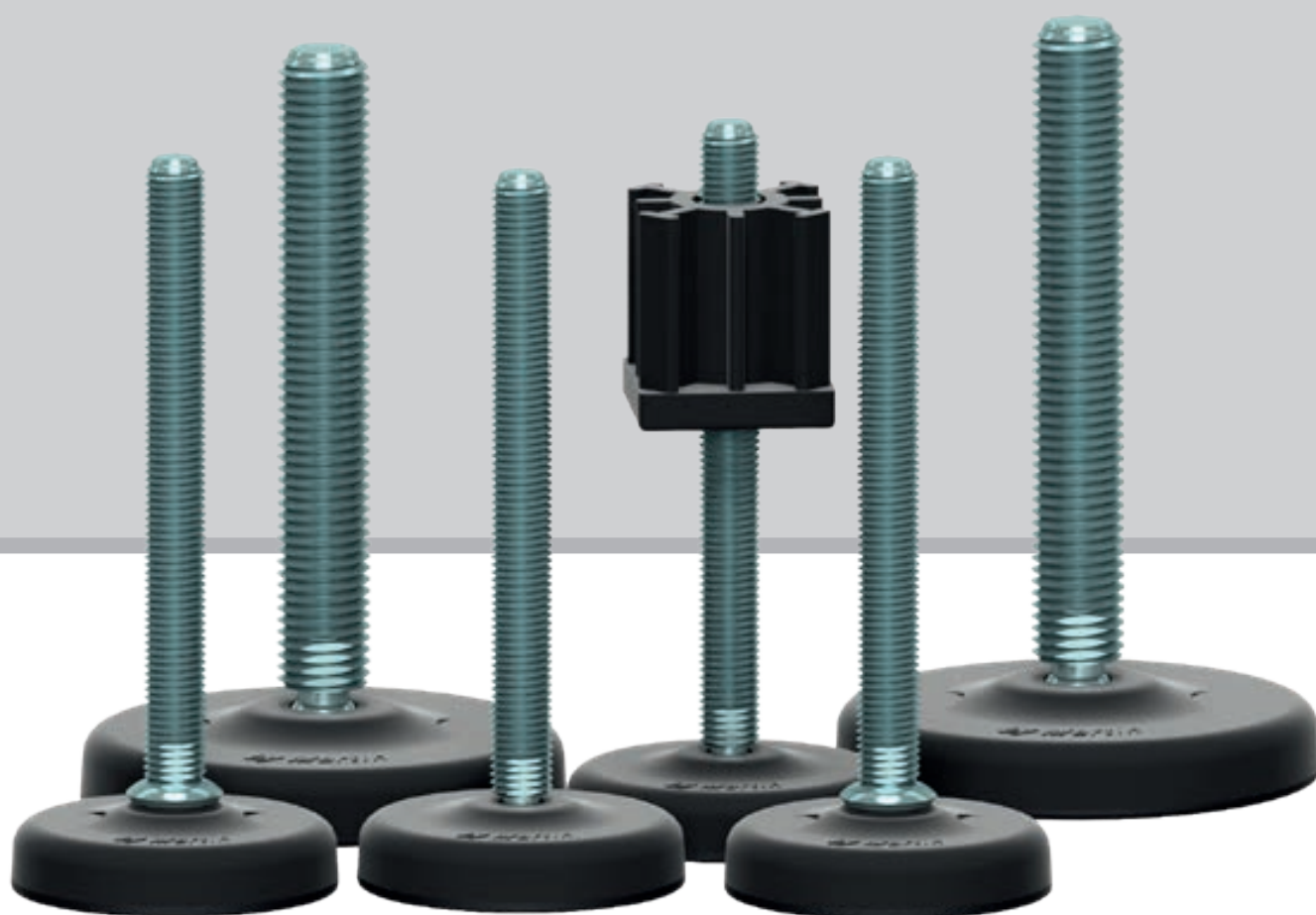

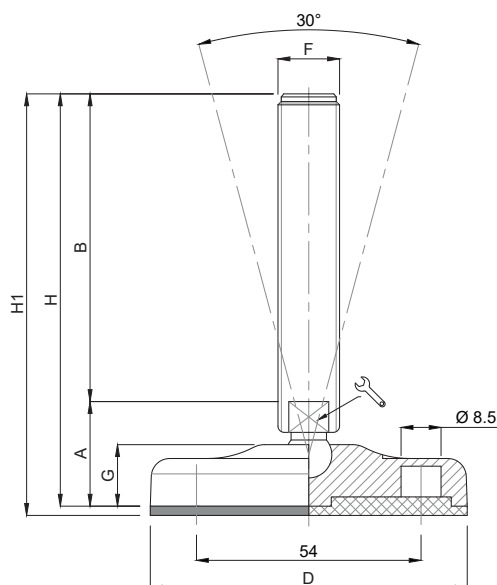

CODICE - CODE		descrizione description	DIMENSIONI PRINCIPALI - MAIN DIMENSIONS								CARICO STATICO STATIC LOAD NEWTON
standard standard	antiscivolo antislip		A	B	D	Ø 8.5	F	G	H	H1	
18500	18501	M10x50	30	50	Ø 83	8	M10	18	80	83	10000
18504	18505	M10x100	30	100	Ø 83	8	M10	18	130	133	10000
18508	18509	M10x150	30	150	Ø 83	8	M10	18	180	183	10000
18512	18513	M12x50	30	50	Ø 83	10	M12	18	80	83	13000
18516	18517	M12x100	30	100	Ø 83	10	M12	18	130	133	13000
18520	18521	M12x150	30	150	Ø 83	10	M12	18	180	183	13000
18524	18525	M16x100	30	100	Ø 83	13	M16	18	130	133	16000
18528	18529	M16x150	30	150	Ø 83	13	M16	18	180	183	16000
18532	18533	M16x200	30	200	Ø 83	13	M16	18	230	233	16000
18536	18537	M20x100	32	100	Ø 83	17	M20	18	132	135	18000
18540	18541	M20x150	32	150	Ø 83	17	M20	18	182	185	18000
18544	18545	M20x200	32	200	Ø 83	17	M20	18	232	235	18000
18548	18549	M20x250	32	250	Ø 83	17	M20	18	282	285	18000

• Materiale base: poliammide rinforzato con sfera di vetro. A richiesta disponibile con gomma antiscivolo NBR 70 shore (codice standard = senza gomma). Materiale stelo: acciaio zincato FE. Su richiesta l'elemento di livellamento viene fornito con dado in acciaio.

• I valori dei carichi sopra riportati sono calcolati in condizioni statiche alla metà della lunghezza dello stelo filettato. Qualora s'intendesse utilizzare i supporti in presenza di vibrazioni o carichi in movimento, tali valori dovranno essere adeguatamente ridotti. Per ulteriori chiarimenti consultare il nostro ufficio tecnico. Ogni nostra responsabilità decade in caso di manomissioni o modifiche dei componenti.

• Base in black polyamide material, reinforced by sphere glass. On request non-skid plate in NBR rubber 70 shore is available (Standard code = without rubber). Galvanized steel screw. The leveling element could be supplied, on request, with steel nut.

• Load values above mentioned have to be considered referring to static conditions calculated at the half of the screw length. In conditions of vibrations or in presence of dynamic loads these values should be reduced. For further information consult our technical office. We cannot accept responsibility for mounts that have been tampered or modified.

Caratteristiche: BASE RIBASSATA Ø 103, STELO SNODATO 30°

Features: LOW-PROFILE BASE Ø 103, 30° ARTICULATED STEM

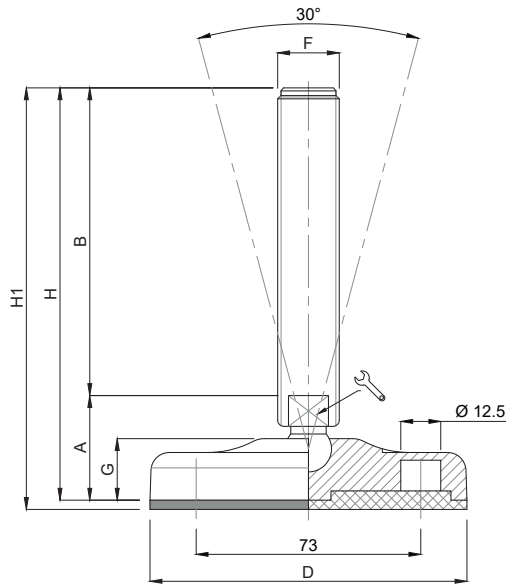

CODICE - CODE		descrizione description	DIMENSIONI PRINCIPALI - MAIN DIMENSIONS								CARICO STATICO STATIC LOAD NEWTON
standard standard	antiscivolo antislip		A	B	D	Ø	F	G	H	H1	
18550	18551	M16x100	32	100	Ø 103	13	M16	20	132	135	18000
18554	18555	M16x150	32	150	Ø 103	13	M16	20	182	185	18000
18558	18559	M16x200	32	200	Ø 103	13	M16	20	232	235	18000
18562	18563	M20x100	34	100	Ø 103	17	M20	20	134	137	20000
18566	18567	M20x150	34	150	Ø 103	17	M20	20	184	187	20000
18570	18571	M20x200	34	200	Ø 103	17	M20	20	234	237	20000
18574	18575	M20x250	34	250	Ø 103	17	M20	20	284	287	20000
18578	18579	M24x100	37	100	Ø 103	20	M24	20	137	140	25000
* 18582	18583	M24x150	37	150	Ø 103	20	M24	20	187	190	25000
* 18586	18587	M24x200	37	200	Ø 103	20	M24	20	237	240	25000
18590	18591	M24x250	37	250	Ø 103	20	M24	20	287	290	25000

* Disponibile con Filettatura a passo fine. Aggiungere "/P2" al codice
Available with Thin pitch thread. Please, add "/P2" to the code

- Materiale base: poliammide rinforzato con sfera di vetro. A richiesta disponibile con gomma antiscivolo NBR 70 shore (codice standard = senza gomma). Materiale stelo: acciaio zincato FE. Su richiesta l'elemento di livellamento viene fornito con dado in acciaio.
- I valori dei carichi sopra riportati sono calcolati in condizioni statiche alla metà della lunghezza dello stelo filettato. Qualora s'intendesse utilizzare i supporti in presenza di vibrazioni o carichi in movimento, tali valori dovranno essere adeguatamente ridotti. Per ulteriori chiarimenti consultare il nostro ufficio tecnico. Ogni nostra responsabilità decade in caso di manomissioni o modifiche dei componenti.
- Base in black polyamide material, reinforced by sphere glass. On request non-skid plate in NBR rubber 70 shore is available (Standard code = without rubber). Galvanized steel screw. The leveling element could be supplied, on request, with steel nut.
- Load values above mentioned have to be considered referring to static conditions calculated at the half of the screw length. In conditions of vibrations or in presence of dynamic loads these values should be reduced. For further information consult our technical office. We cannot accept responsibility for mounts that have been tampered or modified.

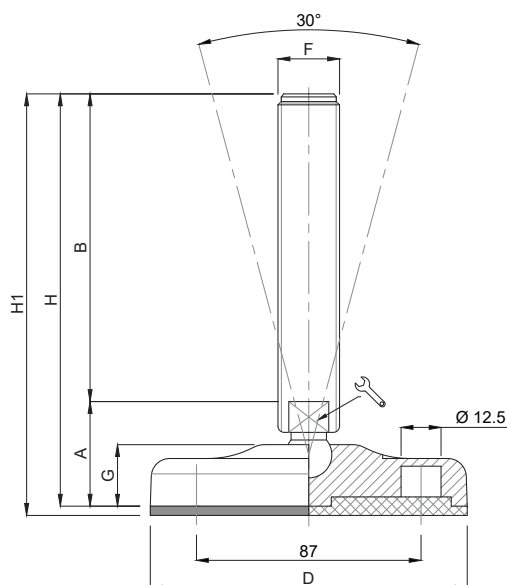

CODICE - CODE		descrizione description	DIMENSIONI PRINCIPALI - MAIN DIMENSIONS								CARICO STATICO STATIC LOAD NEWTON
standard standard	antiscivolo antislip		A	B	D		F	G	H	H1	
18600	18601	M16x100	34	100	Ø 123	13	M16	22	134	137	18000
18604	18605	M16x150	34	150	Ø 123	13	M16	22	184	187	18000
18608	18609	M16x200	34	200	Ø 123	13	M16	22	234	237	18000
18612	18613	M20x100	36	100	Ø 123	17	M20	22	136	139	20000
18616	18617	M20x150	36	150	Ø 123	17	M20	22	186	189	20000
18620	18621	M20x200	36	200	Ø 123	17	M20	22	236	239	20000
18624	18625	M20x250	36	250	Ø 123	17	M20	22	286	289	20000
18628	18629	M24x100	39	100	Ø 123	20	M24	22	139	142	25000
* 18632	18633	M24x150	39	150	Ø 123	20	M24	22	189	192	25000
* 18636	18637	M24x200	39	200	Ø 123	20	M24	22	239	242	25000
18640	18641	M24x250	39	250	Ø 123	20	M24	22	289	292	25000
18644	18645	M30x100	39	100	Ø 123	26	M30	22	139	142	25000
* 18648	18649	M30x150	39	150	Ø 123	26	M30	22	189	192	25000
* 18652	18653	M30x200	39	200	Ø 123	26	M30	22	239	242	25000
18656	18657	M30x250	39	250	Ø 123	26	M30	22	289	292	25000

* Disponibile con Filettatura a passo fine. Aggiungere "/P2" al codice
Available with Thin pitch thread. Please, add "/P2" to the code

- Materiale base: poliammide rinforzato con sfera di vetro. A richiesta disponibile con gomma antiscivolo NBR 70 shore (codice standard = senza gomma). Materiale stelo: acciaio zincato FE. Su richiesta l'elemento di livellamento viene fornito con dado in acciaio.
- I valori dei carichi sopra riportati sono calcolati in condizioni statiche alla metà della lunghezza dello stelo filettato. Qualora s'intendesse utilizzare i supporti in presenza di vibrazioni o carichi in movimento, tali valori dovranno essere adeguatamente ridotti. Per ulteriori chiarimenti consultare il nostro ufficio tecnico. Ogni nostra responsabilità decade in caso di manomissioni o modifiche dei componenti.
- Base in black polyamide material, reinforced by sphere glass. On request non-skid plate in NBR rubber 70 shore is available (Standard code = without rubber). Galvanized steel screw. The leveling element could be supplied, on request, with steel nut.
- Load values above mentioned have to be considered referring to static conditions calculated at the half of the screw length. In conditions of vibrations or in presence of dynamic loads these values should be reduced. For further information consult our technical office. We cannot accept responsibility for mounts that have been tampered or modified.

Caratteristiche: BASE SEMISNODATA Ø 65, STELO SNODATO 16°

Features: HALF-ARTICULATED BASE Ø 65, 16° ARTICULATED STEM

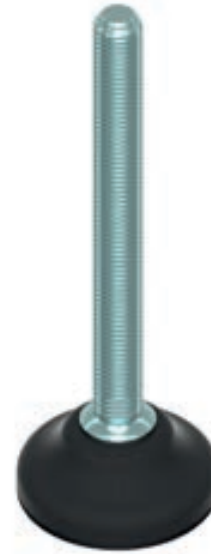
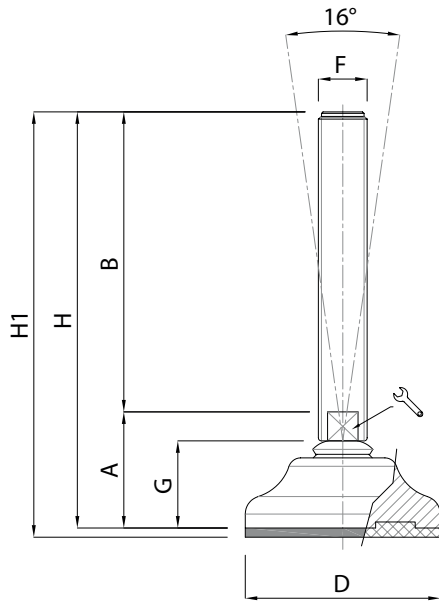

CODICE - CODE	DESCRIZIONE description	DIMENSIONI PRINCIPALI - MAIN DIMENSIONS								CARICO STATICO STATIC LOAD NEWTON
		A	B	D		F	G	H	H1	
18660/65 - 18661/65	M12x50	39	50	ø 65	10	M12	29	89	92	13000
18664/65 - 18665/65	M12x100	39	100	ø 65	10	M12	29	139	142	13000
18668/65 - 18669/65	M12x150	39	150	ø 65	10	M12	29	189	192	13000
18672/65 - 18673/65	M16x100	39	100	ø 65	13	M16	29	139	142	18000
18676/65 - 18677/65	M16x150	39	150	ø 65	13	M16	29	189	192	18000
18680/65 - 18681/65	M16x200	39	200	ø 65	13	M16	29	239	242	18000
18684/65 - 18685/65	M20x100	41	100	ø 65	17	M20	29	141	144	18000
18688/65 - 18689/65	M20x150	41	150	ø 65	17	M20	29	191	194	18000
18692/65 - 18693/65	M20x200	41	200	ø 65	17	M20	29	241	244	18000
18696/65 - 18697/65	M20x250	41	250	ø 65	17	M20	29	291	294	18000
18700/65 - 18701/65	M24x100	41	100	ø 65	20	M24	29	141	144	18000
* 18704/65 - 18705/65	M24x150	41	150	ø 65	20	M24	29	191	194	18000
* 18708/65 - 18709/65	M24x200	41	200	ø 65	20	M24	29	241	244	18000
18712/65 - 18713/65	M24x250	41	250	ø 65	20	M24	29	291	294	18000

* Disponibile con Filettatura a passo fine. Aggiungere "/P2" al codice
Available with Thin pitch thread. Please, add "/P2" to the code

- Materiale base: poliammide rinforzato con sfera di vetro. A richiesta disponibile con gomma antiscivolo NBR 70 shore (codice standard = senza gomma). Materiale stelo: acciaio zincato FE. Su richiesta l'elemento di livellamento viene fornito con dado in acciaio.
- I valori dei carichi sopra riportati sono calcolati in condizioni statiche alla metà della lunghezza dello stelo filettato. Qualora s'intendesse utilizzare i supporti in presenza di vibrazioni o carichi in movimento, tali valori dovranno essere adeguatamente ridotti. Per ulteriori chiarimenti consultare il nostro ufficio tecnico. Ogni nostra responsabilità decade in caso di manomissioni o modifiche dei componenti.
- Base in black polyamide material, reinforced by sphere glass. On request non-skid plate in NBR rubber 70 shore is available (Standard code = without rubber). Galvanized steel screw. The leveling element could be supplied, on request, with steel nut.
- Load values above mentioned have to be considered referring to static conditions calculated at the half of the screw length. In conditions of vibrations or in presence of dynamic loads these values should be reduced. For further information consult our technical office. We cannot accept responsibility for mounts that have been tampered or modified.

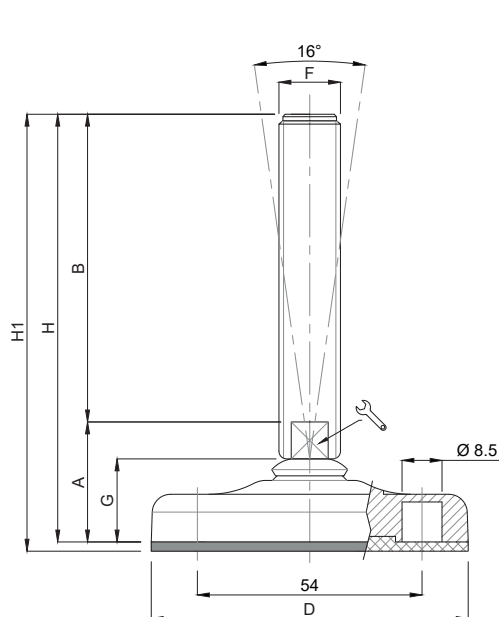

CODICE - CODE		descrizione description	DIMENSIONI PRINCIPALI - MAIN DIMENSIONS								CARICO STATICO STATIC LOAD NEWTON
standard standard	antiscivolo antislip		A	B	D		F	G	H	H1	
18660	18661	M12x50	35	50	Ø 83	10	M12	25	85	88	14000
18664	18665	M12x100	35	100	Ø 83	10	M12	25	135	138	14000
18668	18669	M12x150	35	150	Ø 83	10	M12	25	185	188	14000
18672	18673	M16x100	35	100	Ø 83	13	M16	25	135	138	20000
18676	18677	M16x150	35	150	Ø 83	13	M16	25	185	188	20000
18680	18681	M16x200	35	200	Ø 83	13	M16	25	235	238	20000
18684	18685	M20x100	37	100	Ø 83	17	M20	25	137	140	20000
18688	18689	M20x150	37	150	Ø 83	17	M20	25	187	190	20000
18692	18693	M20x200	37	200	Ø 83	17	M20	25	237	240	20000
18696	18697	M20x250	37	250	Ø 83	17	M20	25	287	290	20000
18700	18701	M24x100	37	100	Ø 83	20	M24	25	137	140	25000
* 18704	18705	M24x150	37	150	Ø 83	20	M24	25	187	190	25000
* 18708	18709	M24x200	37	200	Ø 83	20	M24	25	237	240	25000
18712	18713	M24x250	37	250	Ø 83	20	M24	25	287	290	25000

* Disponibile con Filettatura a passo fine. Aggiungere "/P2" al codice
Available with Thin pitch thread. Please, add "/P2" to the code

- Materiale base: poliammide rinforzato con sfera di vetro. A richiesta disponibile con gomma antiscivolo NBR 70 shore (codice standard = senza gomma). Materiale stelo: acciaio zincato FE. Su richiesta l'elemento di livellamento viene fornito con dado in acciaio.
- I valori dei carichi sopra riportati sono calcolati in condizioni statiche alla metà della lunghezza dello stelo filettato. Qualora s'intendesse utilizzare i supporti in presenza di vibrazioni o carichi in movimento, tali valori dovranno essere adeguatamente ridotti. Per ulteriori chiarimenti consultare il nostro ufficio tecnico. Ogni nostra responsabilità decade in caso di manomissioni o modifiche dei componenti.
- Base in black polyamide material, reinforced by sphere glass. On request non-skid plate in NBR rubber 70 shore is available (Standard code = without rubber). Galvanized steel screw. The leveling element could be supplied, on request, with steel nut.
- Load values above mentioned have to be considered referring to static conditions calculated at the half of the screw length. In conditions of vibrations or in presence of dynamic loads these values should be reduced. For further information consult our technical office. We cannot accept responsibility for mounts that have been tampered or modified.

Caratteristiche: BASE RIBASSATA Ø 103, STELO SNODATO 16°

Features: LOW-PROFILE BASE Ø 103, 16° ARTICULATED STEM

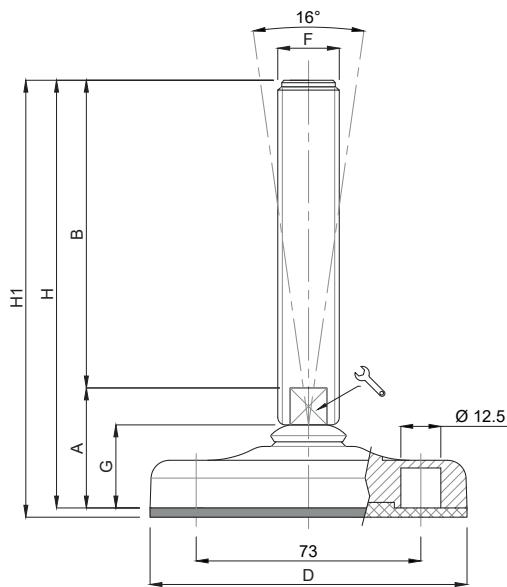

CODICE - CODE		descrizione description	DIMENSIONI PRINCIPALI - MAIN DIMENSIONS								CARICO STATICO STATIC LOAD NEWTON
standard standard	antiscivolo antislip		A	B	D		F	G	H	H1	
18720	18721	M16x100	37	100	Ø 103	13	M16	27	137	140	30000
18724	18725	M16x150	37	150	Ø 103	13	M16	27	187	190	30000
18728	18729	M16x200	37	200	Ø 103	13	M16	27	237	240	30000
18732	18733	M20x100	39	100	Ø 103	17	M20	27	139	142	30000
18736	18737	M20x150	39	150	Ø 103	17	M20	27	189	192	30000
18740	18741	M20x200	39	200	Ø 103	17	M20	27	239	242	30000
18744	18745	M20x250	39	250	Ø 103	17	M20	27	289	292	30000
18748	18749	M24x100	39	100	Ø 103	20	M24	27	139	142	30000
* 18752	18753	M24x150	39	150	Ø 103	20	M24	27	189	192	30000
* 18756	18757	M24x200	39	200	Ø 103	20	M24	27	239	242	30000
18760	18761	M24x250	39	250	Ø 103	20	M24	27	289	292	30000

* Disponibile con Filettatura a passo fine. Aggiungere "/P2" al codice
Available with Thin pitch thread. Please, add "/P2" to the code

• Materiale base: poliammide rinforzato con sfera di vetro. A richiesta disponibile con gomma antiscivolo NBR 70 shore (codice standard = senza gomma). Materiale stelo: acciaio zincato FE. Su richiesta l'elemento di livellamento viene fornito con dado in acciaio.

• I valori dei carichi sopra riportati sono calcolati in condizioni statiche alla metà della lunghezza dello stelo filettato. Qualora s'intendesse utilizzare i supporti in presenza di vibrazioni o carichi in movimento, tali valori dovranno essere adeguatamente ridotti. Per ulteriori chiarimenti consultare il nostro ufficio tecnico. Ogni nostra responsabilità decade in caso di manomissioni o modifiche dei componenti.

• Base in black polyamide material, reinforced by sphere glass. On request non-skid plate in NBR rubber 70 shore is available (Standard code = without rubber). Galvanized steel screw. The leveling element could be supplied, on request, with steel nut.

• Load values above mentioned have to be considered referring to static conditions calculated at the half of the screw length. In conditions of vibrations or in presence of dynamic loads these values should be reduced. For further information consult our technical office. We cannot accept responsibility for mounts that have been tampered or modified.

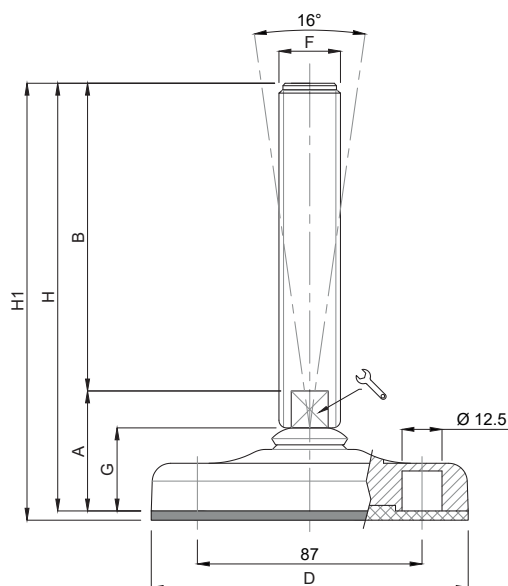

CODICE - CODE		descrizione description	DIMENSIONI PRINCIPALI - MAIN DIMENSIONS								CARICO STATICO STATIC LOAD NEWTON
standard standard	antiscivolo antislip		A	B	D	Ø	F	G	H	H1	
18770	18771	M16x100	39	100	Ø 123	13	M16	29	139	143	35000
18774	18775	M16x150	39	150	Ø 123	13	M16	29	189	193	35000
18778	18779	M16x200	39	200	Ø 123	13	M16	29	239	243	35000
18782	18783	M20x100	41	100	Ø 123	17	M20	29	141	145	35000
18786	18787	M20x150	41	150	Ø 123	17	M20	29	191	195	35000
18790	18791	M20x200	41	200	Ø 123	17	M20	29	241	245	35000
18794	18795	M20x250	41	250	Ø 123	17	M20	29	291	295	35000
18798	18799	M24x100	41	100	Ø 123	20	M24	29	141	145	35000
* 18802	18803	M24x150	41	150	Ø 123	20	M24	29	191	195	35000
* 18806	18807	M24x200	41	200	Ø 123	20	M24	29	241	245	35000
18810	18811	M24x250	41	250	Ø 123	20	M24	29	291	295	35000
18814	18815	M30x100	41	100	Ø 123	26	M30	29	141	145	35000
* 18818	18819	M30x150	41	150	Ø 123	26	M30	29	191	195	35000
* 18822	18823	M30x200	41	200	Ø 123	26	M30	29	241	245	35000
18826	18827	M30x250	41	250	Ø 123	26	M30	29	291	295	35000

* Disponibile con Filettatura a passo fine. Aggiungere "/P2" al codice
Available with Thin pitch thread. Please, add "/P2" to the code

- Materiale base: poliammide rinforzato con sfera di vetro. A richiesta disponibile con gomma antiscivolo NBR 70 shore (codice standard = senza gomma). Materiale stelo: acciaio zincato FE. Su richiesta l'elemento di livellamento viene fornito con dado in acciaio.
- I valori dei carichi sopra riportati sono calcolati in condizioni statiche alla metà della lunghezza dello stelo filettato. Qualora s'intendesse utilizzare i supporti in presenza di vibrazioni o carichi in movimento, tali valori dovranno essere adeguatamente ridotti. Per ulteriori chiarimenti consultare il nostro ufficio tecnico. Ogni nostra responsabilità decade in caso di manomissioni o modifiche dei componenti.
- Base in black polyamide material, reinforced by sphere glass. On request non-skid plate in NBR rubber 70 shore is available (Standard code = without rubber). Galvanized steel screw. The leveling element could be supplied, on request, with steel nut.
- Load values above mentioned have to be considered referring to static conditions calculated at the half of the screw length. In conditions of vibrations or in presence of dynamic loads these values should be reduced. For further information consult our technical office. We cannot accept responsibility for mounts that have been tampered or modified.

Caratteristiche: BASE Ø 83/103/123

Features: BASE Ø 83/103/123 with anti-vibration rubber

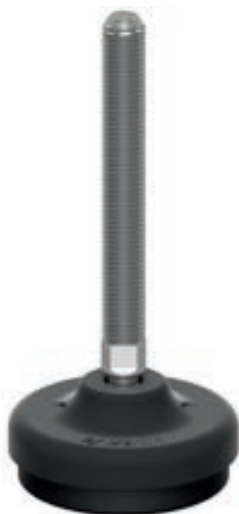

Ø 83 PORTATA 5000 N
Ø 83 LOAD CAPACITY 5000 N



Ø 103 PORTATA 10000 N
Ø 103 LOAD CAPACITY 10000 N



Ø 123 PORTATA 12000 N
Ø 123 LOAD CAPACITY 12000 N

**Teknoeasy nasce per eliminare i problemi di vibrazioni
dove non ci siano esigenze di carichi pesanti**

Applicazione: compressori, alimentatori, vibratori, autodistributori, macchine per pulitura ecc.

*Teknoeasy is the right solution in contexts of light medium loads
Applications: compressors, feeders, vibrators, cleaning machines a.s.o.*

per ordinare è sufficiente aggiungere "/1" al codice standard.
Esempio: base plastica Ø 83, stelo In ferro zincato m20x200
codice standard... 10318 - codice Teknoeasy... 10318/1

*to make your order you just have to add a /1 to the standard CODE.
Example: Standard leveling 10318: plastic base d.83 screw M20x200
Teknoeasy CODE: 10318/1*

- Materiale base: poliammide rinforzata con fibre di vetro. Gomma NBR 70 shore
- Plastic base reinforced by fiber glass; anti-vibration pad NBR 70 shore

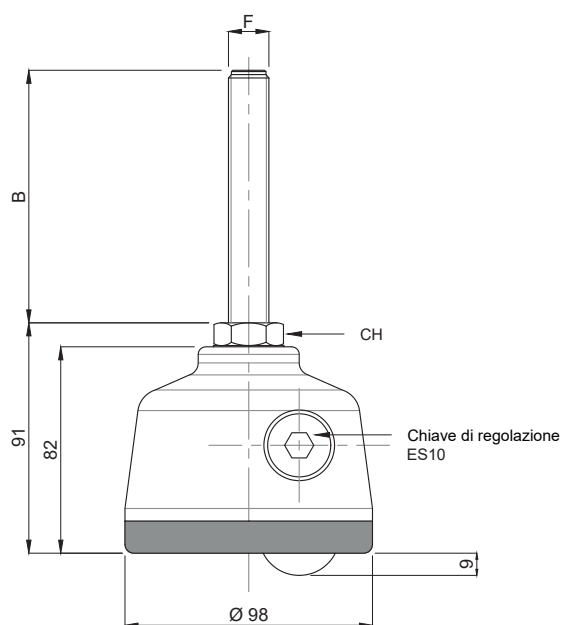

CODICE	DESCRIZIONE	DIMENSIONI PRINCIPALI			CARICO STATICO NEWTON
		CH	F	B	
01FR2	PIEDE RUOTA M16x50 ANTIVIBRANTE	24	M16	50	1500
02FR2	PIEDE RUOTA M16x100 ANTIVIBRANTE	24	M16	100	1500
03FR2	PIEDE RUOTA M20x75 ANTIVIBRANTE	24	M20	75	1500
04FR2	PIEDE RUOTA M20x125 ANTIVIBRANTE	24	M20	125	1500
05FR2	PIEDE RUOTA M24x75 ANTIVIBRANTE	24	M24	75	1500
06FR2	PIEDE RUOTA M24x125 ANTIVIBRANTE	24	M24	125	1500

Su richiesta disponibile con stelo Acciaio Inox AISI 304
Available with stainless steel stem AISI 304 (1.4301)

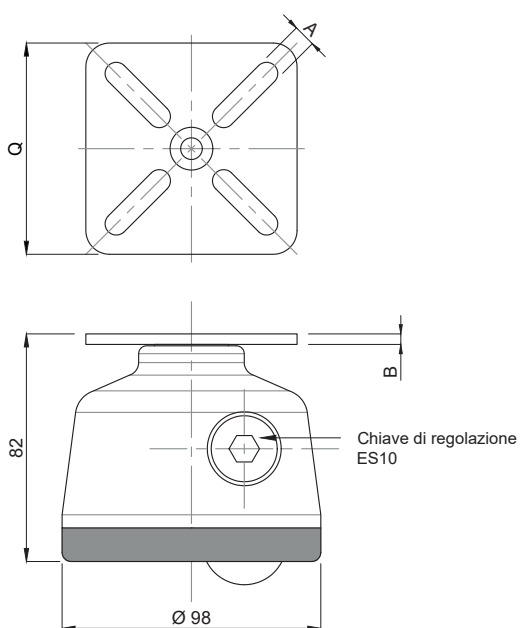

CODICE - CODE	DESCRIZIONE - description	DIMENSIONI PRINCIPALI MAIN DIMENSIONS		
		A	Q	B
020.PF80x80	PIEDE RUOTA CON PIASTRA DI FISSAGGIO	8,5	80x80	4

ATTENZIONE  WARNING

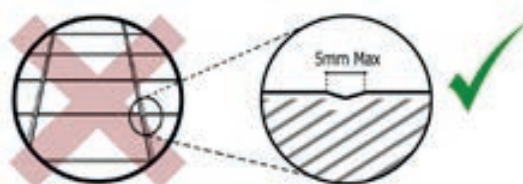

facile e veloce

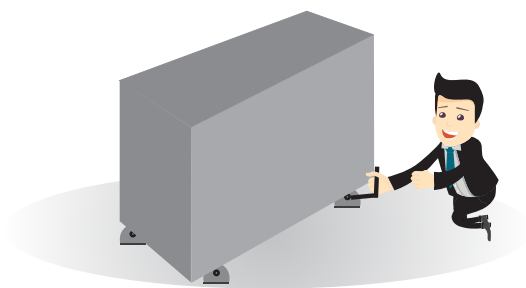

easy and fast

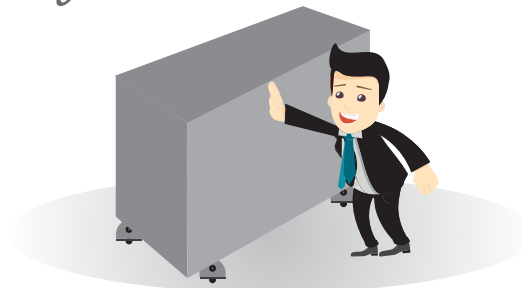

Vantaggi:

- Flessibilità
- Velocità di azione
- Risparmio di tempo
- Riduzione della forza lavoro per l'installazione del macchinario
- Estetica gradevole

Pros:

- Flexibility
- Speed of action
- Time saving
- Less manpower to move the structure around
- Attractive design

Morskate®

Gedreven door techniek



Any questions? Please contact us.

Morskate Aandrijvingen BV

Oosterveldsingel 47A
7558 PJ Hengelo (Ov)
The Netherlands

NL

T +31 (0)74 - 760 11 11
info@morskateaandrijvingen.nl
www.morskateaandrijvingen.nl

DE

T +49 692 - 222 34 95
info@morskateantriebstechnik.de
www.morskateantriebstechnik.de

EN

T +31 (0)74 - 760 11 11
info@morskatedrivetechnology.com
www.morskatedrivetechnology.com